

**Standard Technical Specifications for CCT Emulsifier**

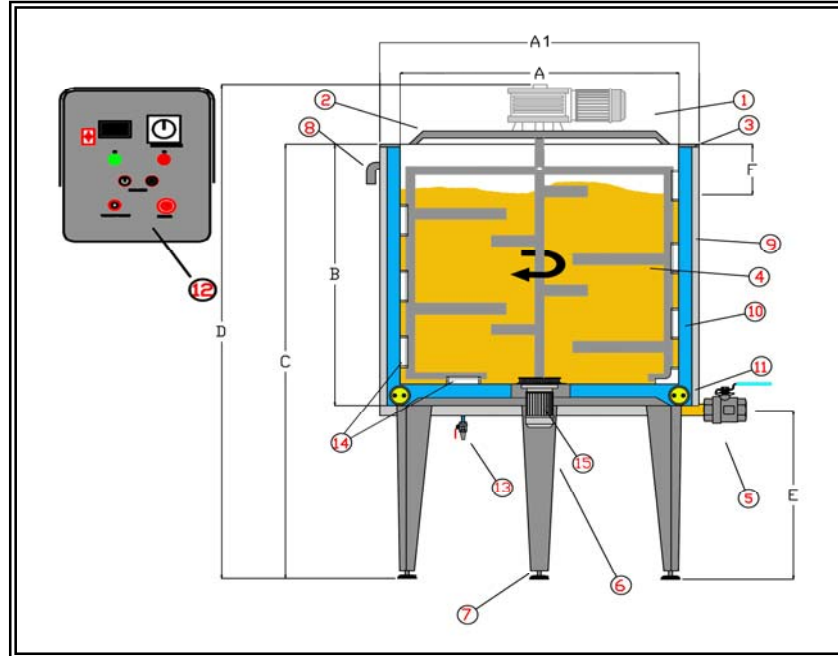

CCT 500	A1	A	B	C	D	E	F	Voltage-Power cons.
	1068	928	960	1490	1690	380	200	220-380 V 7,0 Kw
1	Variable speed mixing motor with electronic control ( 5-10 Rpm )							
2	Support for mixing motor with oil containment							
3	Reinforced top edge profile							
4	Mixing anchor with opposid blades							
5	Drain tap with clamp connection							
6	Support legs							
7	levelling feet							
8	Water jacket overflow							
9	Thermal insulation							
10	Water jacket overflow							
11	Electrical water heating							
12	Control Panel							
13	Water jacket inlet							
14	Interchangeables teflon scrapers							
15	Variable speed emulsifier motor ( 200 - 900 ) with electronic control							

Cylindriycal frameworks 304 Stainless Steel	
Internal surface finish: polished	External surface finish: Satin
Saafety plane cover in two pieces with oversize opening	
Control panel complete with: Main switch, safety stop, setting and display of temperature for water bath ( CFR ) Control lamp indication, speed regulation for mixing and emulsifier motor.	

**Optional Accessories as below indicated :**

Cylindrical framework 316 Stainles Steel	Spray-ball for internal washing
Mixing by impellor having different size and inclination on request.	
Product temperature display	Weighting system and relative display
Other speed options available for emulsifier	

**P.S .Dimensions subject to change**